

# #4500 BULLET SIZER & LUBRICATOR

## Assembly

Your new #4500 Bullet Sizer and Lubricator has been fully assembled at the factory. However, to facilitate packaging and shipping, the handle has been dismounted. Installation of the handle is quick and easy - simply align the handle with the link (**Figure 21**) and turn in the handle until it stops. No other assembly steps are required.

NOTE: Lyman's #4500 is intended only for the sizing and lubrication of bullets cast of lead - tin - antimony alloy and the installation of gas checks where required.

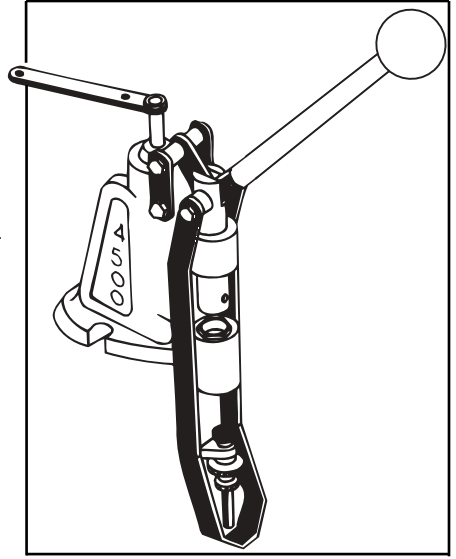

## Bench Mounting

Full benefit of your #4500's leverage cannot be realized unless your bench is both strong and stable. Position your #4500 over the edge of the bench. Two 3/8" bolts, with washers and nuts, firmly anchor the machine. (Mounting bolts not included.)

## Installing the Top Punch

Use the supplied allen wrench to loosen the set-screw in the front of the lower end of the ram. Press the smaller upper (numbered) end of the top punch into the hole in the ram and tighten the set-screw. The top punch should closely match the nose shape of the bullet to be sized.

## Installing the Sizing Die Assembly

Remove the die retaining nut (**Figure 22**) and insert the sizing die assembly into the recess in the base of the casting as shown. Be certain the end of the sizing die which contains the rubber "O" ring is up. Carefully replace the die retaining nut. Screw it in with your fingers to prevent cross-threading. When the retaining nut is finger-tight, use the flat box wrench to tighten it more securely. Caution - Do not over-tighten this nut.

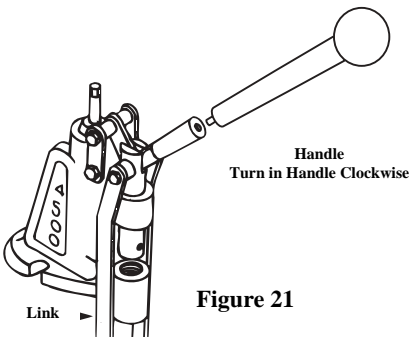

Figure 21

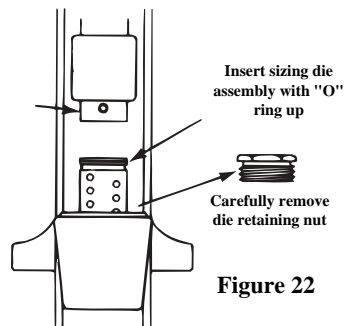

Figure 22

## #4500 Sizer/Lubricator (continued)

### Removing the Sizing Die

If you wish to remove the sizing die, unscrew the die retaining nut. Place your flat box wrench (on its edge) under the push rod and on top of the knockout link. Holding the wrench in this position as you pull up on the operating handle will eject the sizing die.

### Inserting Lubricant

**WARNING:** Lyman recommends the use of the N.R.A. formula Alox Bullet Lube or the Lyman Ideal Bullet Lube for use with the 4500 Lube Sizer.

Hard bullet lubes, if used, must be heated before use. Failure to do so, may damage your lubricator and void the warranty.

The first bullet you run into a new sizing die should always be lightly lubricated to prevent sticking. Using your fingers, remove a small amount of lubricant from your stick of lube. Then take one of the bullets that you will be sizing and lubricating and lightly coat the outside of the bullet rings only. Do not fill the grooves with lubricant.

Lyman Bullet Lubricant is recommended for use in your new Sizer and Lubricator. The lubricant is supplied specifically moulded to fit the reservoir of the #4500 tool.

**Figure 23** shows how to insert a stick of bullet lubricant into your machine. Remove the reservoir cap and place the ratchet wrench on the pressure screw as shown. Turn the wrench clockwise until the pressure piston is free from the threaded portion of the screw.

Remove this piston and slide a stick of bullet lubricant (removed from plastic) over the pressure screw and down into the reservoir. Replace the piston on the pressure screw and press down until it engages the threaded portion of the screw. Turn the ratchet wrench counterclockwise until the pressure piston is within the reservoir and then replace the reservoir cap.

### Operating Your #4500 Sizer Lubricator

Place a cast bullet (base down) in position in the center of the sizing die, on top of the bottom punch. The first bullet you run into a new bullet sizer die should be lightly lubricated by hand to prevent sticking. Pull the operating handle down so the bullet is forced down into the sizing die. Hold down firmly on the operating handle while you turn the ratchet wrench counterclockwise to force lubricant into the bullet grooves. If the tool's frame is entirely empty of lubricant, grease must fill this space before it will reach the bullet. Turn the wrench until pressure is built up. When this space is filled, the increased pressure will make the wrench hard to turn and thus be felt by the operator.

Raise your handle and remove your bullet for inspection. If the top grooves are not receive

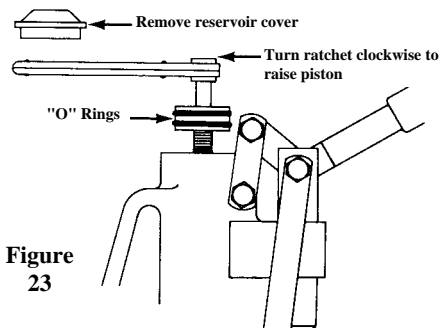

**Figure 23**

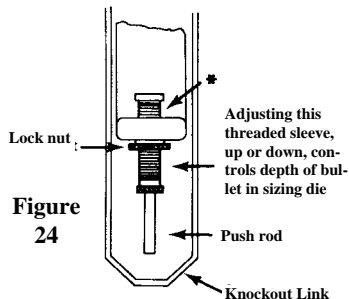

**Figure 24**

## #4500 Sizer/Lubricator (continued)

ing grease, lower the threaded push rod adjustment screw shown in **Figure 24**. Repeat the adjustment, a little at a time, until the driving bands are sized and all the grooves between them are properly filled with lubricant.

Care should be used when adjusting depth to insure that the lube does not run over onto the nose of the bullet. When the setting is correct, tighten the adjusting screw lock nut and proceed with your sizing and lubricating.

**Note:** Do not operate in cold weather or until lubricant has been allowed to reach room temperature of approximately 70 degrees.

### Attaching Gas Checks

You may attach gas checks to your bullets while sizing and lubricating. Simply set the gas check (cup end up) in the center of the sizing die and place your bullet over it as you pull down the operating handle. Firm pressure at the bottom of the stroke will usually seat your gas check firmly and evenly.

However, if the gas check will not fully seat on the bullet using only finger pressure, the Lyman Gascheck Seater should be employed for best results.

To install, raise the #4500's push rod until its top bears against the bottom of the sizing die. Then slip the Gascheck Seater around the threaded pushrod adjusting screw so that the push rod is held at the base of the sizing die.

Next, a gascheck is set, cup-side up, in the center of the sizing die and a bullet guided into it as you pull down on the operating handle. Use only enough force to fully seat the gascheck. After all the gaschecks have been installed, remove the Seater and size and lubricate normally.

Use of the Gascheck Seater ensures the squarest-possible bullet base regardless of the type of gaschecks used. A good square bullet base translates into improved accuracy.

The Lyman #4500 Lubricator/Sizer utilizes an 110V or 220V 20 watt heating element to allow easy use of "hard" lubes such as Lyman's Orange Magic. The element is inserted in the bottom, rear portion of the #4500 (see **Figure #25**) and is secured with a 10-32 size allen screw.

**Caution:** Do not over tighten the allen screw. Do not operate heater if not installed into the lubricator/sizer and securely locked in place. Burns can result if operated out of the unit.

Once secured in place, plug in element to a properly grounded outlet for 20-30 minutes before beginning to size bullets. The body of the #4500 should be warm to touch when at proper operating temperatures. Should the bullet lube become too soft, the unit can be unplugged. Once unplugged, the cast iron body of the #4500 will retain its heat for a period of approximately one hour.

### See Page 71 for "Tips"

**Caution:** Do not leave unattended while plugged in.

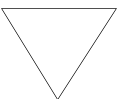

**Tips on Using Your #4500 Sizer**  
**WARNING! See Safety**  
**Instructions Page 57**

**Figure 25**

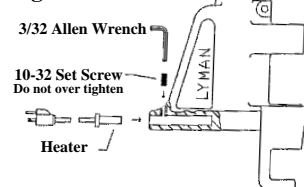

# #4500 LUBRICATOR/SIZER

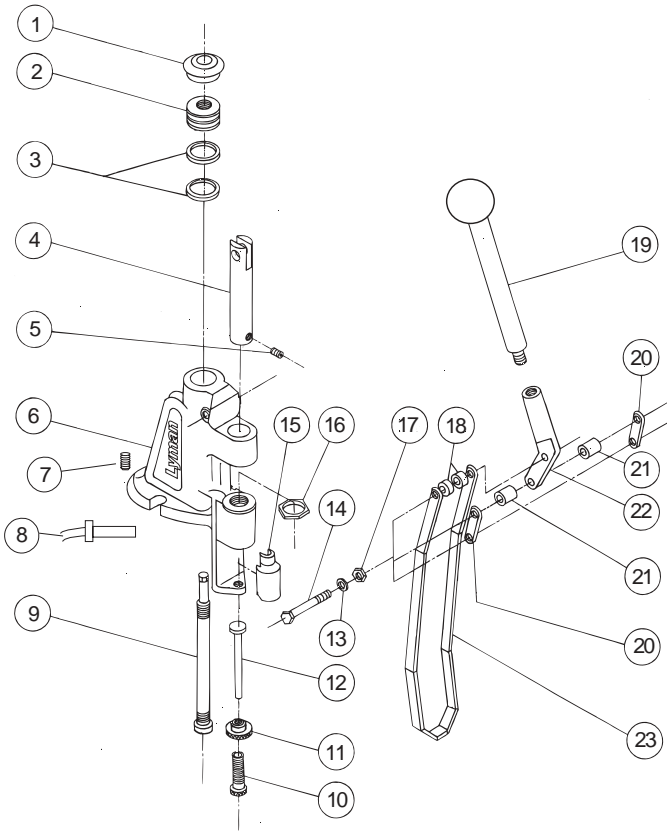

Key	Part Description	Part #	Key	Part Description	Part #
1	Lubricant Reservoir Cover	2990598	15	Gas Check Seater	2745881
2	Pressure Nut	2990146	16	Sizing Die Retaining Nut	2990601
3	O-Ring (2)	2990689	17	Centerlock Nut (3)	2745816P
4	Ram	2745818	18	Spacer, Short (2)	2745809
5	Set Screw	2990622	19	Handle Assembly	2745806
6	Body Casting	2990594	20	Connecting Link (2)	2745811
7	Retaining Screw for Heater	7990121	21	Spacer, Long (2)	2745810
8	Lubricant Heater 110V*	2745896	22	Link	2745815
8	Lubricant Heater 220V*	2745898	23	Bullet Knockout Link	2990604
9	Pressure Screw	2990559			
10	Adjusting Screw	2745807			
11	Adjusting Screw Locknut	2745808			
12	Push Out Rod	2990306			
13	Spring Washer (3)	2990202			
14	Hex Head Bolt (3)	2990620P			
			<b>Not Shown:</b>		
				Ratchet Wrench	2745804
				Combo Wrench	2990520
				Hex Wrench	2998880

\*Optional item

# #450 LUBRICATOR/SIZER

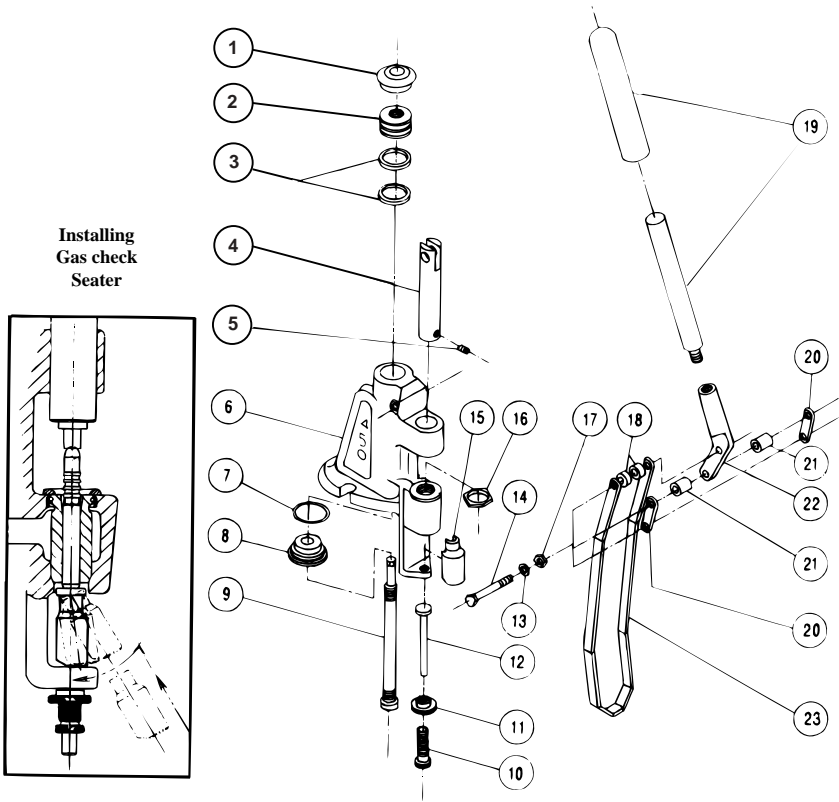

Key	Part Description	Part #	Key	Part Description	Part #
1	Lubricant Reservoir Cover*	2990598	19	Handle with Grip	2745813
2	Pressure Nut*	2990146	20	Connecting Link (2)	2745811
3	O-Ring (2)*	2990689	21	Spacer, Long (2)	2745810
4	Ram	2990593	22	Link	2745815
5	Set Screw	2990622	23	Bullet Knockout Link	2990604
6	Body Casting	2990594			
7	Seal Plug O-Ring*	2990623	<b>Not Shown:</b>		
8	Seal Plug*	2990546		Ratchet Wrench	2745804
9	Pressure Screw*	2990559		Combo Wrench	2990520
10	Adjusting Screw	2745807		Hex Wrench	2998880
11	Adjusting Screw Locknut	2745808			
12	Push Out Rod	2990306			
13	Spring Washer (3)	2990202			
14	Hex Head Bolt (3)	2990620P			
15	Gas Check Seater	2745881			
16	Sizing Die Retaining Nut	2990601			
17	Centerlock Nut (3)	2745816P			
18	Spacer, Short (2)	2745809			

\*These items may be ordered as a complete assembly 2745817

Apply no more pressure on lubricant than is required to “just fill the grooves”. If too much pressure is built up, the lube will accumulate between the base of the bullet and the bottom punch. This condition may also be caused by not holding down firmly on the handle when you apply lubricant pressure. The very least pressure that will fill the grooves is best.

At times there will be portions of the grooves which do not readily fill with lubricant. This is due to trapped air. If those bullets are again cycled through the die, without increasing lubricant pressure, they will fill properly.

Many prefer to work with the lightest lube pressure and raise and lower the bullet twice; the second time without any extra pressure. This produces a perfect job every time.

Never increase lube pressure when the lubricant reservoir is empty or almost empty. If you force the pressure piston down so that it contacts the bottom of the reservoir, you will damage both the pressure screw and the pressure piston.